

STÖGER Screw and assembly systems

Feeder-units ZSE-Series with Vibration bowl

Suitable for all
applications!

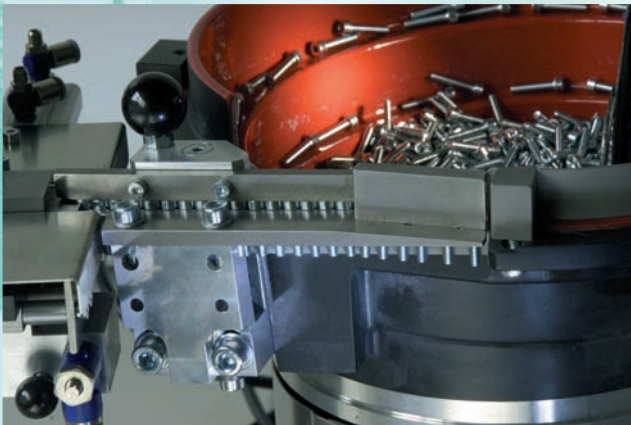

STÖGER
*technology put
to your use !*

STÖGER Advantages

20 years experience

- Service-friendly construction
- Standardised delivery units in all sizes
- Special separation systems for the varied types of fastenings

Project support

We help you plan your project

- Consultation in system decisions per telephone or with a visit
- Price guides for your calculations
- 3D data for your presentation

Investment

Economical alternative

- Use our standardised delivery units with their variable sorting systems as an economical alternative to custom built delivery systems

ZSE 1800 - 2600

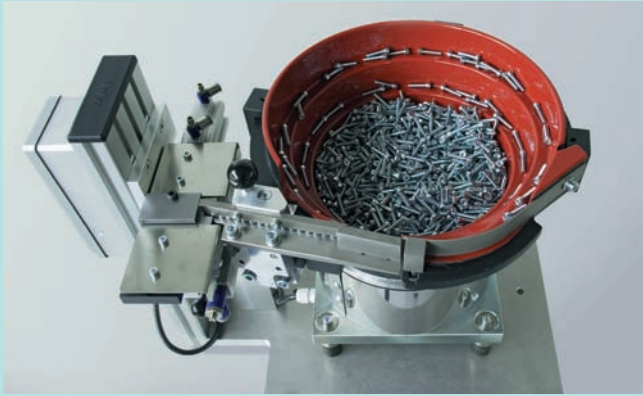

- Surface treated plastic bowl insert
- Hardened and polished delivery rail, adjustable and detachable
- Precise transition from delivery rail to separator
- Detachable and separable sound-insulating cover
- High cycle rate of up to 100 parts/min

Technical Data	ZSE/ ZEM 1000	ZSE/ ZEM 1800	ZSE/ ZEM 2600	ZSE/ ZEM 4000
Feeder bowl dia. (mm)	100	180	260	400
Capacity (litres)	0,05	0,4	1,0	3,0

Custom versions available according to requirements

ZSE 4000

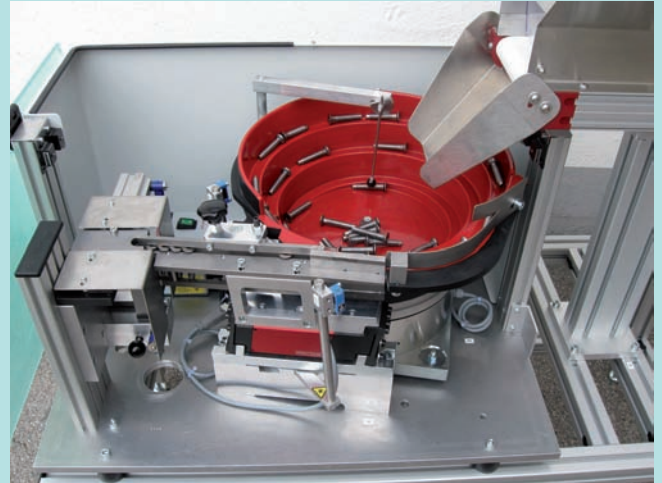

- Sorting chicane as separate linear supply. Plastic bowl insert requires no balancing, giving perfect and finely adjustable running
- Otherwise equipped as ZSE 2600

ZSE 1000 (not illustrated)

- For extremely small fastenings such as screws for spectacles, mobile phones etc.

Linear sorting system

- E.g. for screw-length control with ejection of faulty fastenings



Sword delivery unit

- For fastenings with sensitive surface

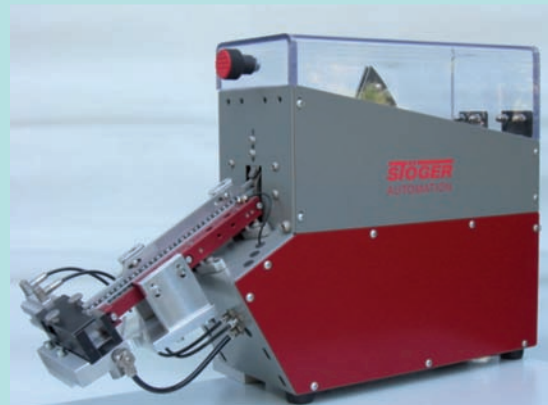

Control units

SGS 4450

- Amplitude unit for simple applications

RGS 46000

- Frequenz unit for sensitive applications



Sorting insert/chicane



- Surface treated plastic bowl insert for even running and wear resistance
- Adjustable sorting chicane with access for easy removal of faulty fastenings



Screws and nuts in all forms and sizes



Rivets, rings, clips, caps, washers, pins, jets, sleeves and and and....

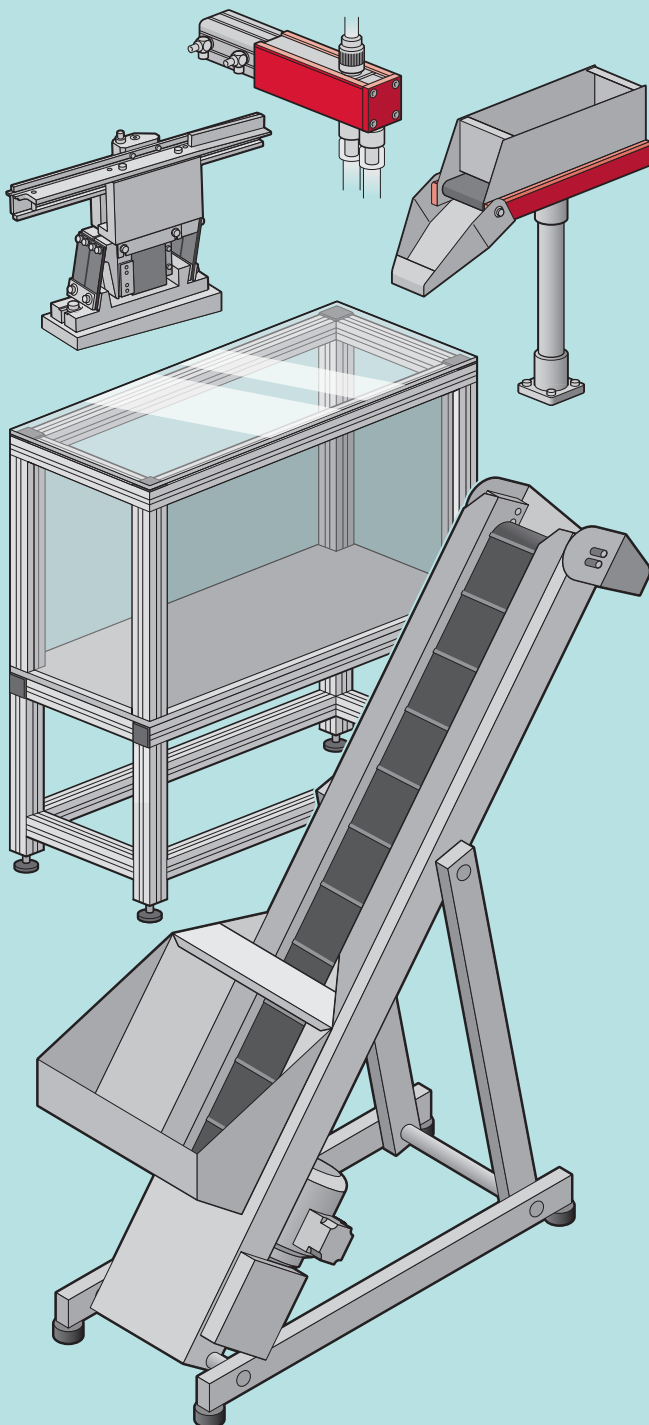

Options

- Hopper

- Capacities 10 - 50 litres
- Reduction of refill intervals
- Constant levels in feeder bowl
- Fastenings carefully handled

- Linear Feeder

- Prevents jamming in delivery rail or feeder bowl
- High- and low-level switching controls operating cycle of feeder bowl
- Fastenings carefully handled

- Distributors

- Distributors for up to 16 systems
- Feed control via ring proximity sensors
- Targeted secondary escapement possible

- Escapement/Special Escapement

- Precise transition from delivery rail
- High cycle rate of up to 100 parts/min
- Simply and quickly dismantled
- Measuring equipment to determine orientation or check dimensions
- Special functions

- Further options

- Optical sorting
- Step feeder
- Sword feeder
- Elevator

Delivery system with separation for flange nuts

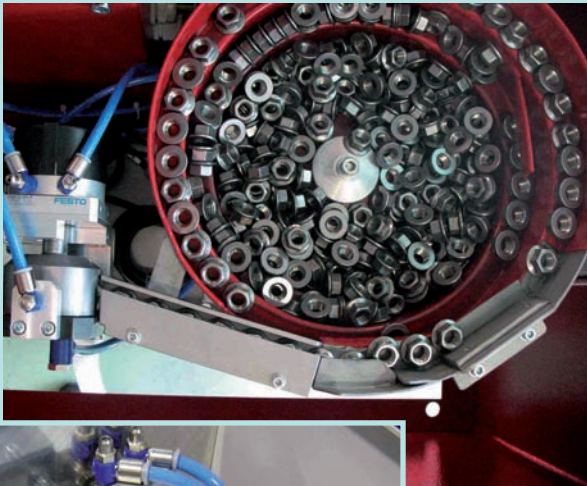

Plastic fasteners for cladding frames in the building industry

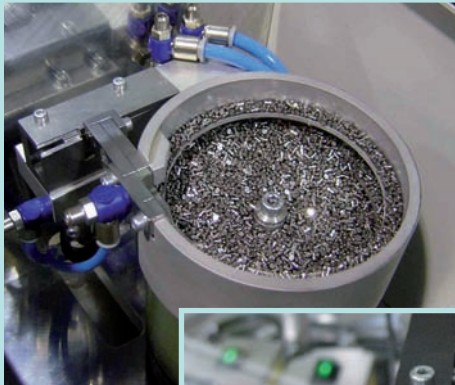
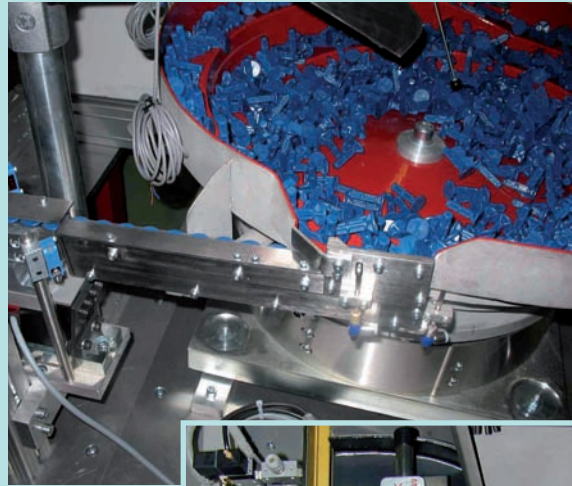

Delivery system ZSE 1000 for pins with 1 mm diameter

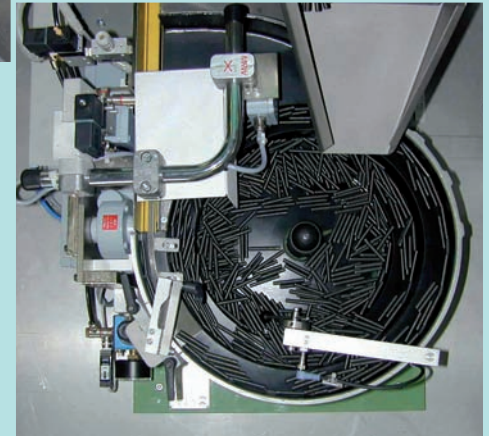

optical sorting with camera



Sorting rail with delivery point for sealing rings

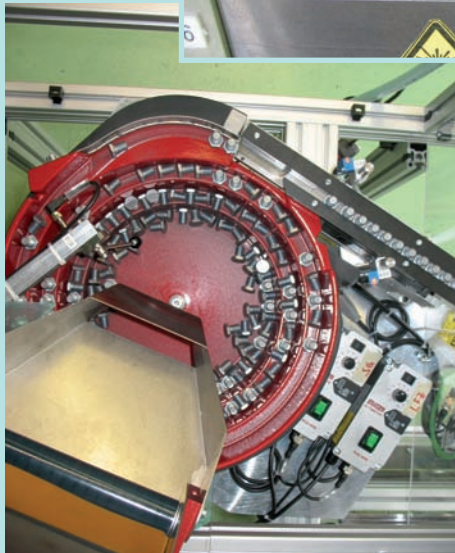

Delivery system for top-heavy screws

TOP 100
We are among the 100 most innovative companies in Germany!



Lorenz Stöger being presented with the award by Lothar Späth

OUR TURN
YOUR ADVANTAGE

STÖGER
AUTOMATION

STÖGER AUTOMATION GmbH · Gewerbering am Brand 1 · D-82549 Königsdorf

☎ ++49(0)8179/99767-0 📠 ++49(0)8179/99767-50 ✉ stoeger@stoeger.com 🌐 www.stoeger.com

20.12.11

