

Adapter to robot shown exemplary

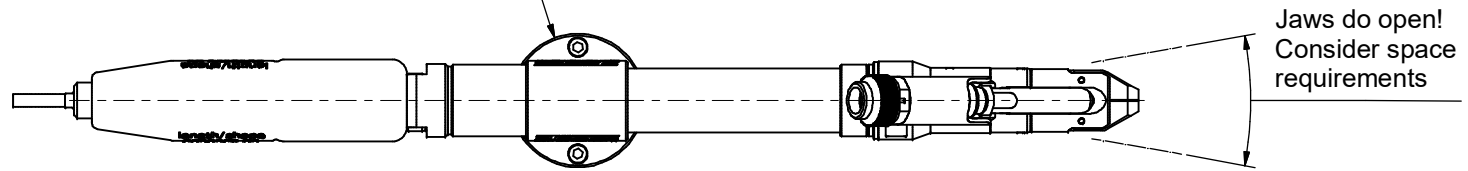

Note 1	
Hose ID (Screw head +1mm)	[R] min. Radius
1,5 - 2,7	95
3,0 - 4,0	100
4,3 - 7,5	110
8,0 - 9,5	150
10,0 - 13,0	200

STÖGER AUTOMATION points out that the model shown is only exemplary and may vary in shape and dimensions depending on the application.  
Weight: approx. 2.8 kg

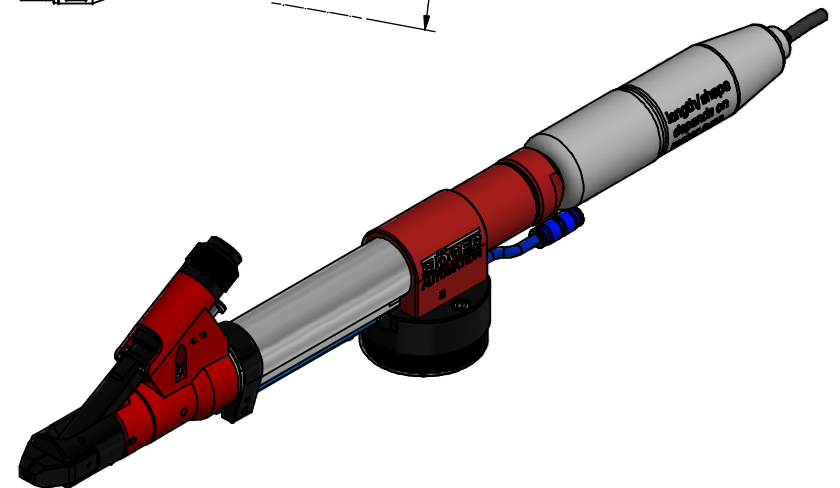

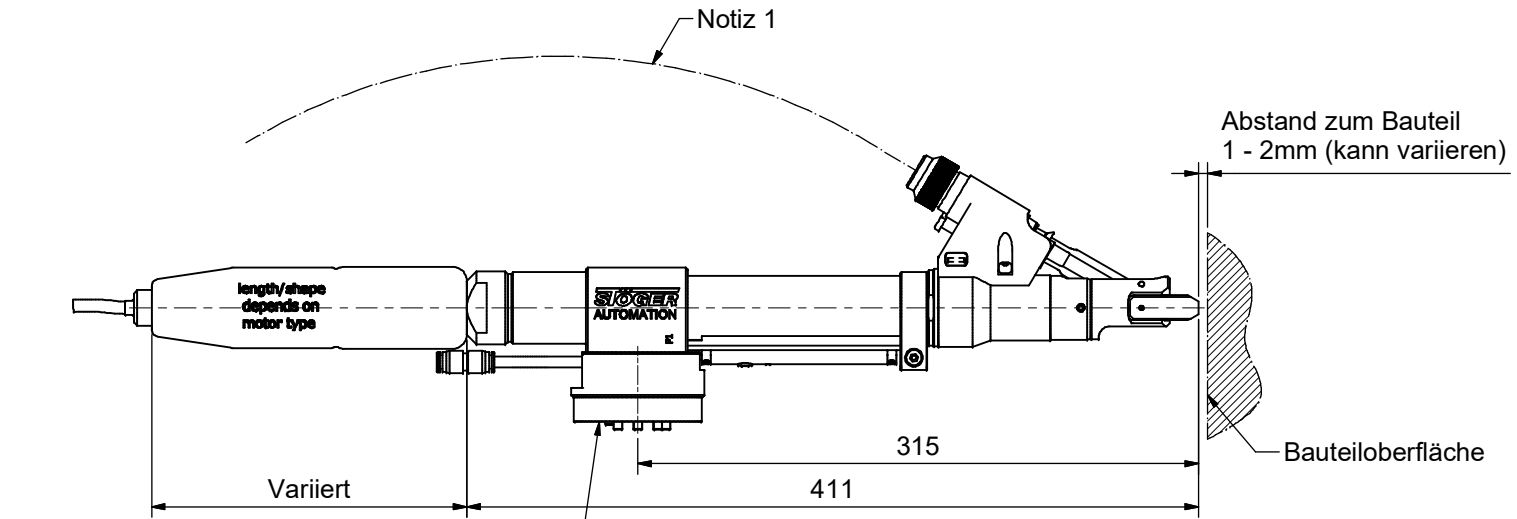

Adapter zum Roboter beispielhaft dargestellt

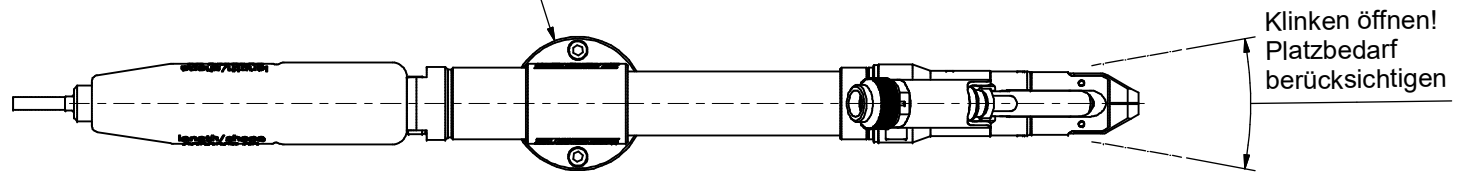

Notiz 1	
Schlauch ID (Schrauben- kopf +1mm)	[R] min. Radius
1,5 - 2,7	95
3,0 - 4,0	100
4,3 - 7,5	110
8,0 - 9,5	150
10,0 - 13,0	200

STÖGER AUTOMATION weist darauf hin, dass das abgebildete Modell nur beispielhaft ist und je nach Anwendungsfall in Form und Abmessungen abweichen kann.  
Gewicht: ca. 2,8 kg

